

Pipe Clamps



Sprinkler Pipe Clamp with Nut



SPRS pipe clamp includes rivet nut.

Application

Used with Fire protection pipes. Designed for suspending pipes allowing for vertical adjustment. The clamp should only be used for horizontal pipe hanging. Loads are complied with NFPA standards.

Mounting Example

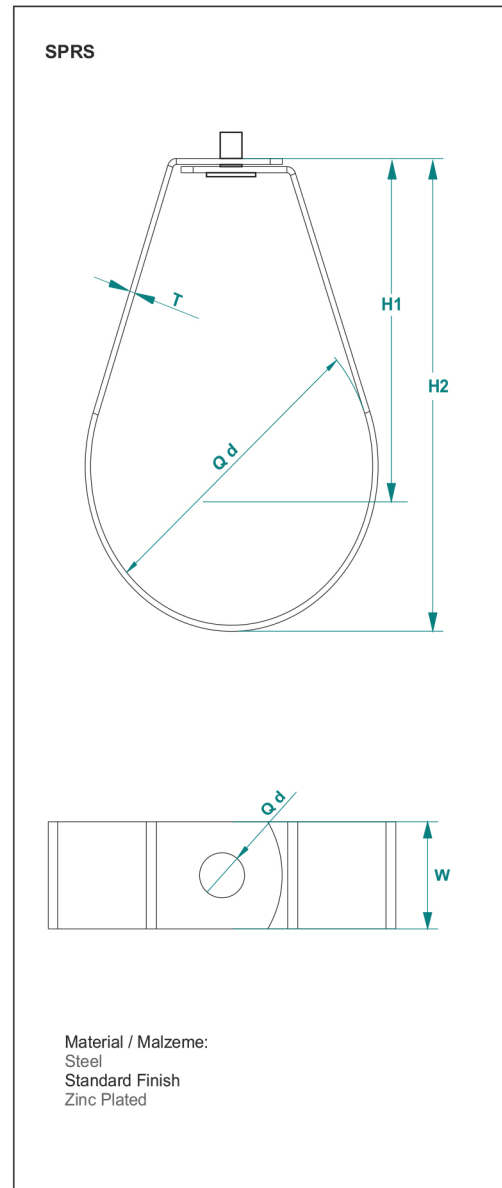
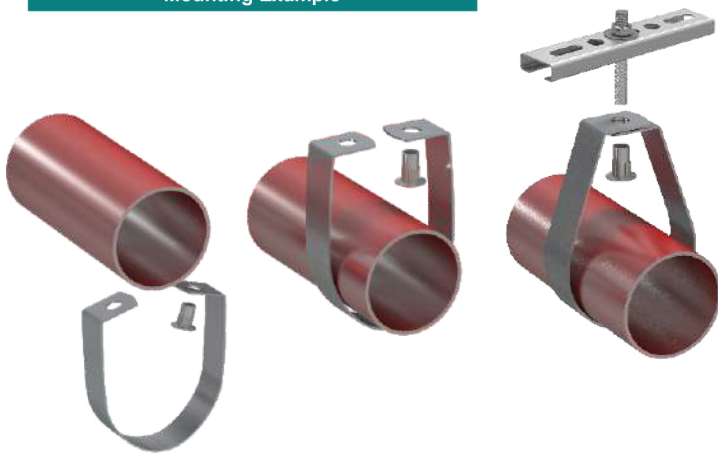

SIZE	DIAMETER (ØD) (mm)	HEIGHT 1 (H1) (mm)	HEIGHT 2 (H2) (mm)	SHEET (TxW) (mm)	NUT ØD (metric)	BREAKING LOAD (kN)	RECOMMENDED LOAD (kN)	QUANTITY PER BOX (pc)	WEIGHT (ORTALAMA / AVARAGE) (kg)
1/2"	28	36,5	51,5	1x25	M10	6,0	1,5	150	6,15
3/4"	30	37,5	53,5	1x25	M10	6,0	1,5	125	5,25
1"	36	46,5	65,5	1x25	M10	6,0	1,5	100	4,80
1 1/4"	46	55,7	79,9	1,2x25	M10	11,0	1,5	75	4,95
1 1/2"	52	58,7	85,9	1,2x25	M10	11,0	1,5	60	4,20
2"	66	65,7	99,9	1,2x25	M10	11,0	1,5	50	4,00
2 1/2"	78	75,5	116	1,5x25	M10	16,0	3,9	35	3,92
3"	92	84,5	132	1,5x25	M10	16,0	3,9	25	3,20
4"	116	107,5	167,5	2x25	M10	19,0	3,9	30	6,24
5"	142	126,5	200	2,5x25	M12	22,0	7,5	30	9,12
6"	170	150,5	238	2,5x25	M12	22,0	7,5	30	10,59
8"	222	197,5	311,5	3x30	M12	25,0	13	10	6,96
10"	275	244	384,5	3x30	M12	25,0	13	15	12,17
12"	324	310	470	3x30	M12	25,0	13	10	9,51